

ALDRIDGE

S-LED Series



Energy Saving Lighting for Tunnels, Underpass, Railway Stations, Adverse Locations & Food Processing Plants

Introducing the S-LED

Introducing the the S-LED and S2-LED the next generation of high level, energy efficient and resilient luminaires for public areas where hygiene and safety is a priority.

The S-LED ideally suited to Pedestrian and Vehicle Underpasses, Railway Stations, Bus Shelters, Transport Hubs, Police Stations and areas of low visibility.

The S-LED facilitates safe movement of vehicles, pedestrians and cyclists, allowing clear identification of objects and people, making it a suitable luminaire for areas prone to crime and vandalism.



Introducing the S2-LED in Stainless Steel

The S2-LED energy efficient luminaire is designed for areas where hygiene and sanitation is a priority.

The S2-LED produces adequate natural light needed for the inspection of cleanliness, whilst the stainless steel housing is easily sanitized. Making this light suitable for the food industry; dairies, brewing, canning and bottling plants, poultry farms, frozen foods, and warehousing as well as chemical and biohazard environments.



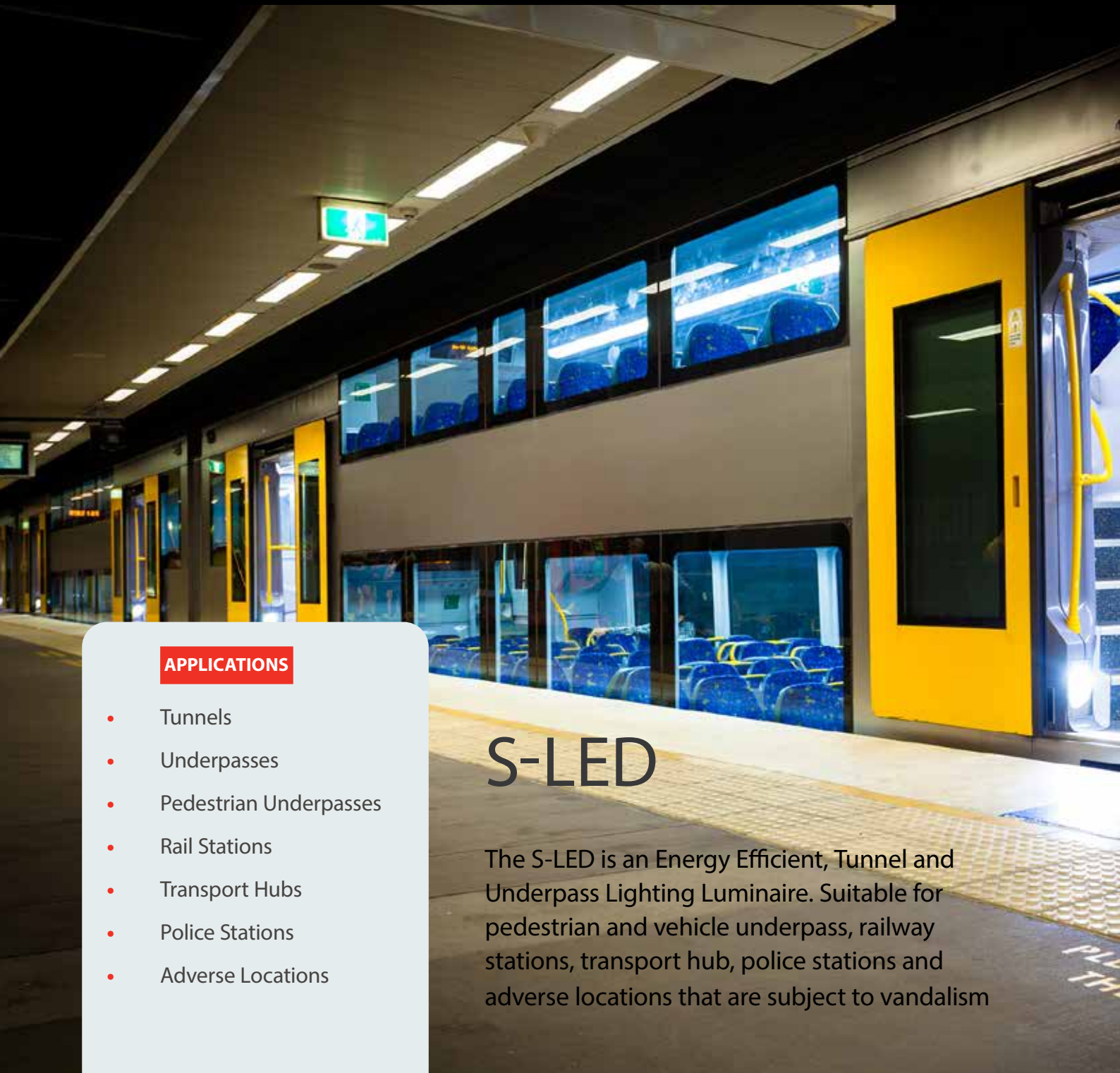

APPLICATIONS

- Tunnels
- Underpasses
- Pedestrian Underpasses
- Rail Stations
- Transport Hubs
- Police Stations
- Adverse Locations

S-LED

The S-LED is an Energy Efficient, Tunnel and Underpass Lighting Luminaire. Suitable for pedestrian and vehicle underpass, railway stations, transport hub, police stations and adverse locations that are subject to vandalism



S-LED Dimensions

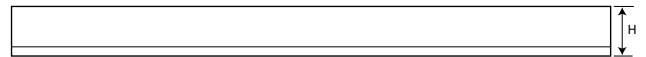

Features

- Suitable for pedestrian and vehicle underpass, railway stations, transport hub, police stations and adverse locations that are subject to vandalism
- Designed to comply with stringent AS/NZ standards
- High performance LED & Optics to meet AS/NZ standards
- Integrated thermal management
- Removable driver and LED module
- End to end mounting
- Smart City compatible - TST
- 10 year warranty

Options

- **Flat diffuser IK10:** (Aero)
- **Fuse Terminal Block:** (FTB)
- **Surge Protection Device:** (SPD - 10KVA, 20KVA)
- **Class II:** (DB - Double Insulated)
- **Colour:** Black (BL), White (WH), Grey (GR - Standard)
- **CCT:** 3000K, **4000K (Standard)**, 5000k
- **Controller:** RS485 compatible lamp driver: (TST:LCU12R)
- **TST compatible:** (TST:SCU02)

Technical Data

- **Body:** Formed Aluminium - Marine Grade
- **Optics:** T2 - T3 - T5
- **Wattage:** 20 - 30 - 40 - 60 Watts
- **Finishing:** Powder Coat (Grey Standard)
- **Fixing:** Ceiling or Wall
- **Mounting:** 3 - 6 Metres
- **IP rating:** IP65
- **IK rating:** IK10
- **Voltage:** 230VAC 50/60Hz
- **Power Factor:** >0.9

Photometric Design Data

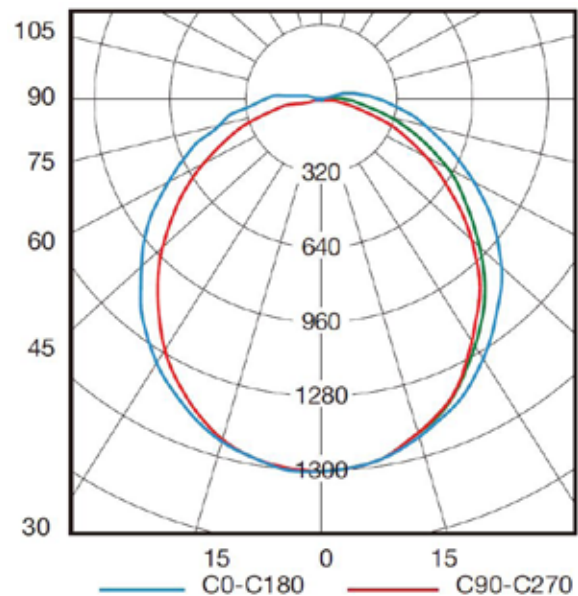

Specification S-LED

PRODUCT CODE	SLED.20W	SLED.30W	SLED.40W	SLED.60W
Dimensions L x W x H mm	1255 x 150 x 90	1255 x 150 x 90	1255 x 150 x 90	1255 x 150 x 90
System Wattage (watts)	20	30	40	60
Input Voltage (V)	230	230	230	230
CCT (K)	4000	4000	4000	4000
CRI	Ra>80	Ra>80	Ra>80	Ra>80
IP Protection	IP65	IP65	IP65	IP65
IK Protection	IK10	IK10	IK10	IK10
Weight (Kg) - max.	8.8	8.8	8.8	8.8



APPLICATIONS

- Manufacturing Plants
- Warehouses
- Depots
- Workshop Areas
- Chemical Plants
- Food Processing Plants
- Canned & Bottled Goods
- Frozen Foods
- Bottling, Brewing & Distilling
- Oil & Fat Processing
- Bakeries
- Dairies

S2-LED

Stainless Steel Luminaire

The S2-LED is an Energy Efficient, Vandal Resistant, Luminaire with high luminous efficiency. The stainless steel housing is also suitable for use in areas where cleanliness is a priority.



S2-LED Dimensions

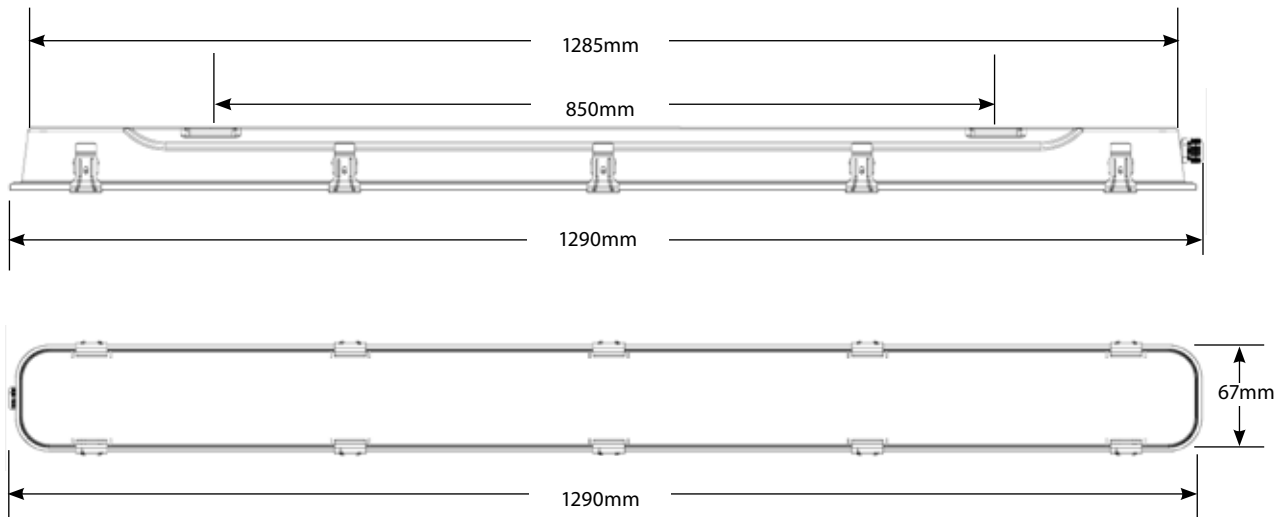

Technical Data

- **Housing:** Stainless steel
- **Diffuser:** Tempered Glass or PC Opal Diffuser - 90°, 120° Beam
- **Beam Angle:** 90° 120°
- **Wattage:** 30 - 60 Watts
- **Finishing:** Stainless Steel
- **Fixing:** Ceiling or Wall
- **CCT:** 2700 ~ 6500K (ANSI C78.377)
- **IP rating:** IP65
- **IK rating:** IK10
- **Input Voltage:** AC 220-240V, 50Hz

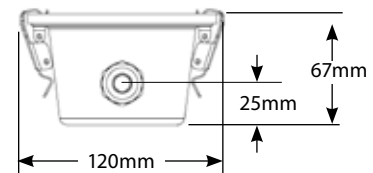

Features

- Vandal Resistant IK10 Rated
- Over 70% Energy Savings Compared to Conventional Batens
- 5 Years Warranty

Specification S2-LED Stainless Steel Luminaire

PRODUCT CODE	S2LED.30W-1200	S2LED.60W-1200
Power (W)+/_10%	30W	60W
Input Voltage/Frequency	AC 220 - 240V, 50Hz/140W	
Installation	Easy and quick to install under ceiling or on surface	
Housing / Diffuser	Stainless steel housing and tempered glass diffuser	
CCT	2700 - 6500K (ANSI C78.377)	
CRI	>80	
PF	PF>0.9	
Beam Angle	90° 120°	
IP Rating	IP65	
Warranty	5 years	
Operating Temperature	-40°C ~ 55°	
Dimensions	1280 x 110 x 65mm	
N.W. (kgs)	3.6	



ALDRIDGE

Aldridge Traffic Systems Pty Ltd

Unit 38, 38-46 South Street
Rydalmere NSW 2116
www.trafficltd.com.au

NSW

P: +61 2 9736 3677
F: +61 2 9736 3391
e: info@trafficltd.com.au

NT

P: +61 8 8947 0733
F: +61 8 8947 0713
e: info@trafficltd.com.au

QLD

P: +61 7 3184 2000
F: +61 7 3266 2244
e: info@trafficltd.com.au

VIC

P: +61 3 9430 0222
F: +61 3 9430 0244
e: info@trafficltd.com.au

ACT

P: +61 2 6299 7922
F: +61 2 6299 7977
e: info@trafficltd.com.au

TAS

P: +61 3 6273 1177
F: +61 3 6273 1759
e: info@trafficltd.com.au

SA

P: +61 8 8362 2385
e: info@trafficltd.com.au

WA

P: +61 8 9248 1002
F: +61 8 9209 2288
e: info@trafficltd.com.au

UNITED KINGDOM

P: +44 (0) 1159 223 797
F: +44 (0) 1159 223 836
e: info@aldrigedgetraffic.co.uk



Accreditation No.
10378

